



## Railway

## Pedestrian Gate

## MRG

Technical Data	Type	MRG
Drive Unit		GTA 210-50
Power Consumption	W	250
Voltage Single Phase	V	110
Thermo Overload	C	100
Frequency	Hz	50/60
Current	A	2.6
Protection	1P	55
Torque Output	Nm	100
Rotation	Deg.	190
Output Shafts	No	2
Duty Cycle	%	50
Opening Time	Sec.	6
Output Torque	Nm	100
Gate Width	mm	1400
Gate Opening	mm	1280
Gate Height	mm	1200

### Description

The MRG series Railway Gates are designed for the control of pedestrian traffic through level and foot crossings, where safety and high usage is of importance.

### Technology

The design of the automatic pedestrian gate is highly vandal resistant, and all components are of robust construction.

The Magnetic Torque drive has a protective indexing clutch and shock absorbing springs built in to prevent internal damage in case the gate is forced against its motion during its operation.

The Torque Motor can be stalled in any position without overheating or suffering any damage.

Torque motors always produce a certain degree of heat so that there is no risk of freezing or condensation – even in cold climatic conditions.

### The Gate

Gate, linkages, drive housing and posts are of robust construction to resist intentional damage by vandals. The gate is manufactured of RHS steel and is hot dip galvanised. The gate hinges are designed for low maintenance with greased bushes and stainless steel pins. Couplings for the lever arms are self aligning and of low maintenance.

The drive system is mounted on a detachable mounting plate for fast exchange if required.

### General Description:

When a train approaches the crossing, a Sonalert located in the drive mechanism sounds, followed by the closing of the gate, to prevent access across the tracks, while exposing the emergency exit.

After the passage of a the train, the Sonalert stops and the gate opens under power, once again exposing the walkway permitting access across the tracks and at the same time closing off the emergency exit.

### On Power failure

During power failure conditions, the gate will automatically close under spring tension.

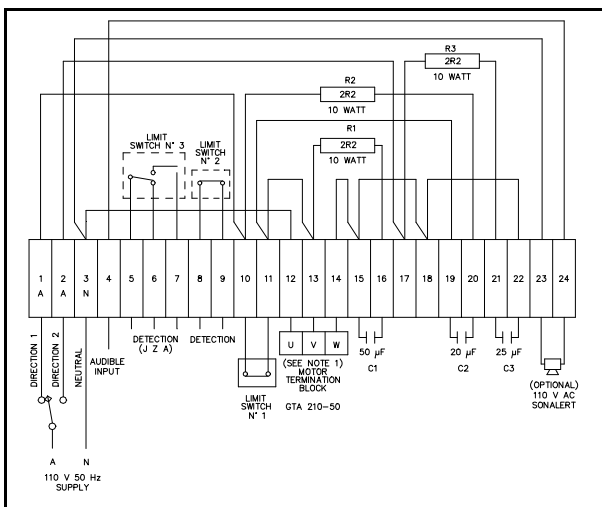
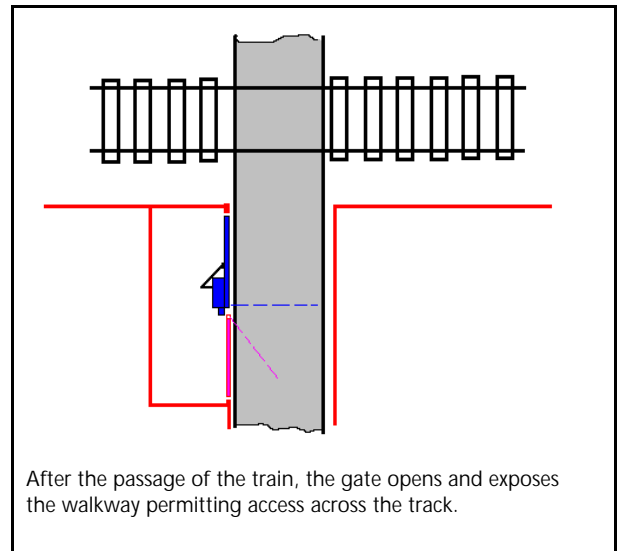
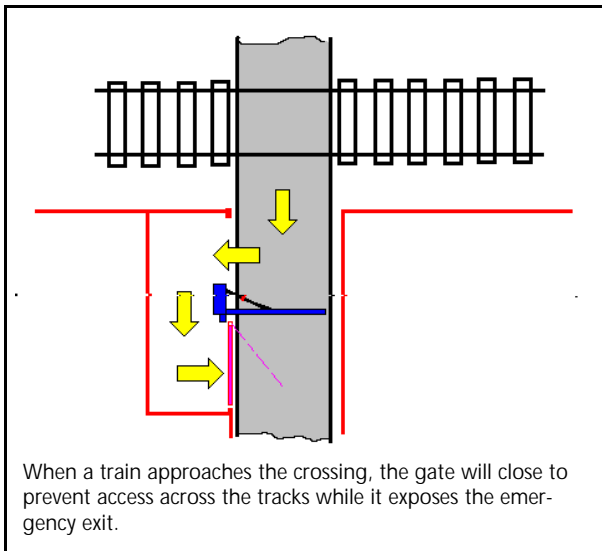
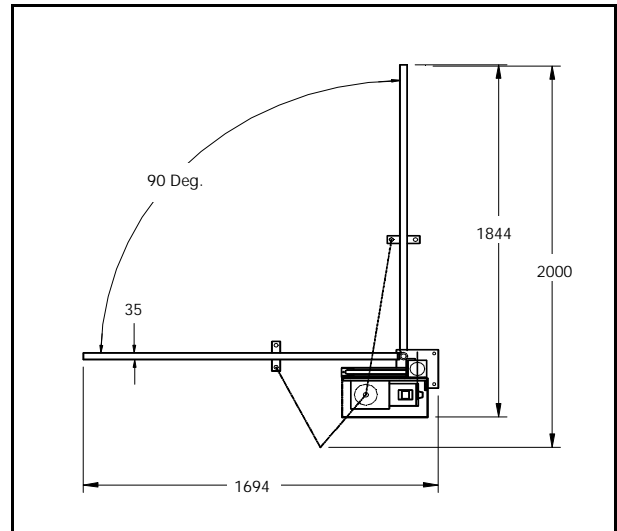
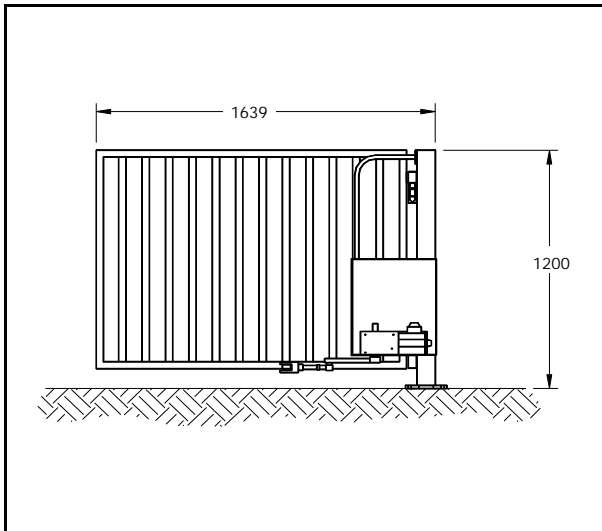

### Electrical Connection

Electrical connection for the standard version of the railway gate is in accordance with the diagram shown adjacent.

2 Potential free limit switches with 1 normally open and 1 normally closed contact are provided for feedback of the position of the gate.

Incoming main supply and hook up should only be performed by a certified electrician.